



# analog RYTM

8 Voice Drum Computer

By Elektron

**GETTING STARTED MANUAL**



MIDI In  
MIDI Out  
Sync A  
MIDI Thru  
Sync B

analog

120.0 FILL RTM DEC SUS REL  
1-100-0000000000000000  
1-100-0000000000000000  
1-100-0000000000000000

8 Voice Drum Computer

Level

Tempo  
Tap

Yes/Save

No/Reload

Bank Group  
Direct Change

Trig Mute  
Accent

Swing

Retrig+

Retrig-

1/Time+

Trig  
Setup

Synth  
Delay

Sample  
Reverb

Filter  
Dist

Amp  
Comp

Copy

Clear

Past

OH10

CY11

MT7

RS3

LT6

HT8

CB12

6

7

8

9

10

11

A

B

F

E

G

LF

LF

## IMPORTANT SAFETY AND MAINTENANCE INSTRUCTIONS

Read these instructions and follow them.

1. Do not use the unit near water.
2. Never use aggressive cleaners on the casing or on the LCD screen. Remove dust, dirt and fingerprints with a soft, dry and non-abrasive cloth. More persistent dirt can be removed with a slightly damp cloth using only water. Disconnect all cables while doing this. Only reconnect them when the product is safely dry.
3. To avoid scratches or damage, never use sharp objects near the casing or the LCD screen. Avoid applying any pressure to the screen itself.
4. Install in accordance with the manufacturer's instructions. Make sure you place the unit on a stable surface before use. If you mount the unit in a rack, be sure to tighten all four screws in the rack mount holes.
5. Connect the unit to an easily accessible electrical outlet close to the unit.
6. In the EU, only use CE approved power cords.
7. When transporting the unit, preferably use accessories recommended by the manufacturer or the box and padding the unit originally shipped with.
8. Do not install near any heat sources such as radiators, heat registers, stoves, or any other appliance (including amplifiers) emitting heat.
9. Do not put the PL-2 Protective Cover (Elektron accessory) on the unit while the unit is powered on.
10. Do not block the ventilation holes located on the side and the bottom of the enclosure of the unit.
11. This product, either alone or in combination with an amplifier and headphones or speakers, may be capable of producing sound levels that can cause permanent hearing loss. Do not operate for a long period of time at a high volume level or at a level that is uncomfortable.
12. Protect the power cord from being walked on or pinched particularly at plugs, convenience receptacles, and the point where they exit from the unit.
13. Use attachments/accessories specified by the manufacturer.
14. Unplug this unit during lightning storms or when it is not used for long periods of time.
15. Refer all servicing to qualified service technicians. Servicing is required when the unit has been damaged in any way, liquid has been spilled or objects have fallen into the unit, the unit has been exposed to rain or moisture, does not operate normally, or has been dropped.

### WARNING

To reduce the risk of fire, electrical shock or product damage:

- Do not expose the unit to rain, moisture, dripping or splashing and also avoid placing objects filled with liquid, such as vases, on the unit.
- Do not expose the unit to direct sunlight, nor use it in ambient temperatures exceeding 30° C as this can lead to malfunction.
- Do not open the casing. There are no user repairable or adjustable parts inside. Leave service and repairs to trained service technicians only.

### SAFETY INSTRUCTIONS FOR THE POWER ADAPTER ELEKTRON PSU-3

- The adapter is not safety grounded and may only be used indoors.
- To ensure good ventilation for the adapter, do not place it in tight spaces. To prevent risk of electric shock and fire because of overheating, ensure that curtains and other objects do not prevent adapter ventilation.
- Do not expose the power adapter to direct sunlight, nor use it in ambient temperatures exceeding 40° C.
- Connect the adapter to an easily accessible electrical outlet close to the unit.
- The adapter is in standby mode when the power cord is connected. The primary circuit is always active as long as the cord is connected to the power outlet. Pull out the power cord to completely disconnect the adapter.

**Elektron machines are sold with a three year limited warranty**, starting from the date of the original purchase. Being able to prove the date of the original purchase with an invoice or a receipt is necessary if you require warranty service. If the machine should need a repair during the warranty period no charges will be applied for parts or labor. This warranty is transferable to other owners should the Elektron machine be resold during the warranty period. Items belonging to the Elektron Style range of products (t-shirts, stickers, posters etc.) are not covered by this warranty.

This warranty does not cover (a) damage, deterioration or malfunction resulting from accident, negligence, misuse, abuse, improper installation or operation or failure to follow instructions according to either the Getting Started manual or the full user manual for this product; any shipment of the product (claims must be presented to the carrier); repair or attempted repair by anyone other than Elektron or a certified Elektron repair center (b) any unit which has been altered or on which the serial number has been defaced, modified or removed; (c) normal wear and any periodic maintenance; (d) deterioration due to perspiration, corrosive atmosphere or other external causes such as extremes in temperature or humidity; (e) damages attributable to power line surge or related electrical abnormalities, lightning damage or acts of God; or (f) RFI/EMI (interference/noise) caused by improper grounding or the improper use of either certified or uncertified equipment, if applicable.

### Warranty service procedure for machines bought from a retailer

Please contact their support if you need warranty service. You will then be guided how to proceed with your errand. Note that the Elektron three year limited warranty is in addition to any warranty your retailer may offer.

### Warranty service procedure for machines bought from the Elektron Online Shop



Contact the Elektron Support at [www.elektron.se](http://www.elektron.se) if you need warranty service. You cannot send a unit to a certified Elektron repair center unless agreed to by Elektron. The customer is responsible for shipping charges if the machine needs to be shipped to a certified Elektron repair center for warranty service. Elektron covers the shipping back to the customer during the warranty period. Should the unit be dead on arrival, or if the hardware malfunctions within 2 weeks of the original purchase date, Elektron will cover the shipping to a certified Elektron repair center.



# analog RYTM

## THANK YOU

---

Thank you for purchasing the Analog Rytm, an eight voice analog/digital hybrid drum machine featuring the twang of the analog domain, the instant control and effects of the digital domain and the wonderful interplay of both. Analog signal path, digital controls, samples and omnipresent modulation makes this drum machine a solid instrument with a voice of its own. For all its layers of complexity and depth, it remains instantly accessible and—we are sure you will agree—fun to play.

This quickstart will guide you through the basics of the machine. The complete user manual is available as a digital download at [www.elektron.se](http://www.elektron.se).

We wish you an awesome hybrid experience. Start tapping those multicolor pads.

—The Elektron Team

# PANEL LAYOUT

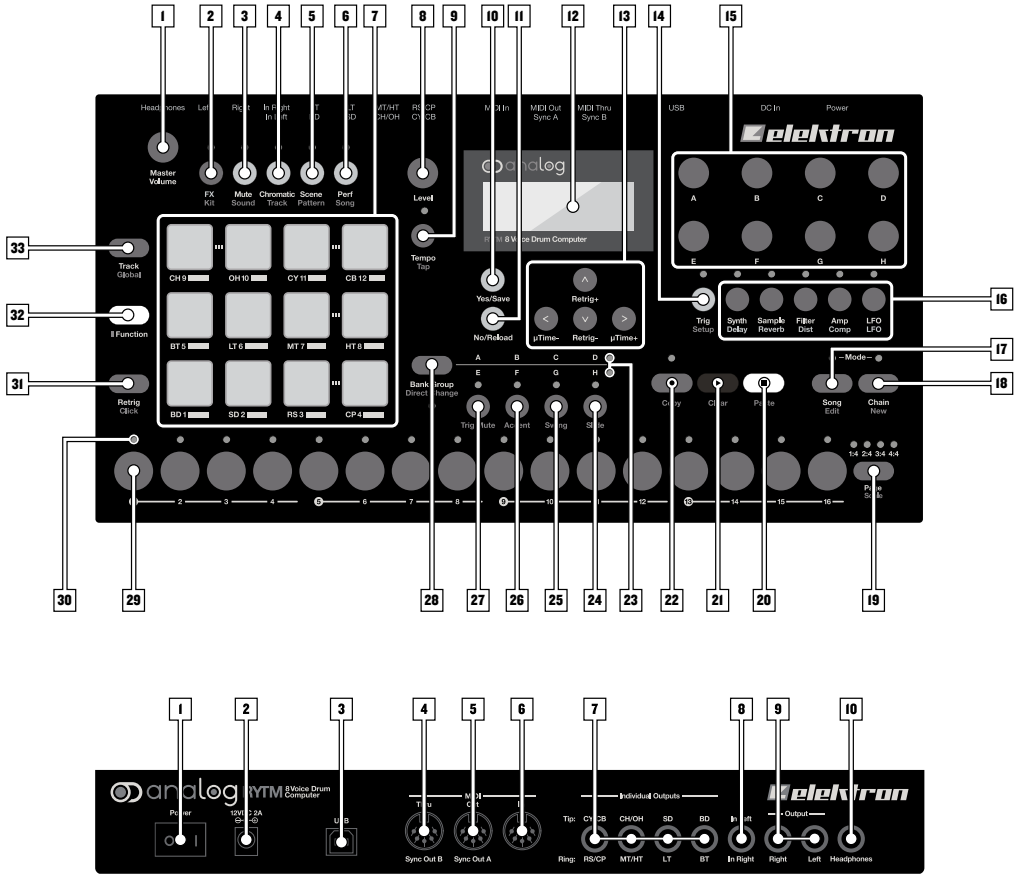

## FRONT PANEL

- 1 MASTER VOLUME** sets the volume for the main outputs and the headphones output.
- 2 [FX]** selects the FX track. Secondary function accesses the KIT menu.
- 3 [MUTE]** activates MUTE mode. SOUND menu is accessed as a secondary function.
- 4 [CHROMATIC]** activates CHROMATIC mode, in which the pads are used to play the current track Sound chromatically across four octaves. Secondary function accesses the TRACK menu.
- 5 [SCENE]** activates SCENE mode, a one-push instant scene change of an array of Sound parameters. Secondary function brings forth the PATTERN menu.
- 6 [PERFORMANCE]** activates PERFORMANCE mode. Secondary function accesses the SONG menu.
- 7 [PADS]** are 12 responsive, assignable, velocity and pressure sensitive synthetic rubber pads with aftertouch. They have many possible functions depending on which mode is active and what each pad is set to do. First of all, they are designed to play the track Sounds. Each drum track has a dedicated pad (see the complete map on page 8). <PADS> will exhibit a variety of colors.
- 8 LEVEL** sets the overall volume level of the active track. Also used for setting parameters and scrolling through lists.
- 9 [TEMPO]** opens the TEMPO menu. Use [FUNCTION] + [TEMPO] to tap the tempo.

- 10 **[YES/SAVE]** key. Used for entering sub-menus, selecting and confirming. Press in combination with 2, 3, 4, 5 or 6 (see above) to instantly save the kit, Sound, track, pattern or song.
- 11 **[NO/RELOAD]** key. Used for exiting an active menu, backing one step and negating. Press in combination with 2, 3, 4, 5 or 6 (see above) to instantly reload the kit, Sound, track, pattern or song.
- 12 The LCD screen.
- 13 The **[ARROW]** keys. Used for navigation and for setting certain parameter values. They are called **[UP]**, **[DOWN]**, **[LEFT]** and **[RIGHT]**.
- 14 **[TRIG SETUP]** key controls the TRIG settings for the active track. Secondary function accesses the TRIGS menu.
- 15 **DATA ENTRY** knobs **A-H**. Used for setting parameter values. Press knob when turning to change values in larger increments.
- 16 **[PARAMETER]** keys access the PARAMETER pages of the active track. <PARAMETER> LEDs directly above the keys indicate if the page is active (red) or inactive (off). The five parameter page keys are, from left to right:

**SYNTH** key for accessing the SYNTH parameters of the track Sound. These control the analog drum synthesis. When the FX track is active, the DELAY parameter page is accessed.

**SAMPLE** key takes you to the SAMPLE page. Various aspects of the sample loaded to the active track are set on this page. When the FX track is active, the REVERB parameter page is accessed.

**FILTER** key accesses the FILTER page. The filter parameters are set here. When the FX track is active, the DISTORTION parameter page is accessed.

**AMP** key takes you to the AMP page, where the shape and function of the amplitude envelope is set. When the FX track is active, the COMPRESSOR parameter page is accessed.

**LFO** key accesses the LFO parameters for the active track.

- 17 **[SONG MODE]** activates/deactivates SONG mode. Secondary function is SONG edit.
- 18 **[CHAIN MODE]** activates/deactivates CHAIN mode. Secondary function initiates a new CHAIN.
- 19 **[PAGE]** selects the active pattern page, if the pattern is made of more than 16 steps. <PATTERN PAGE> LEDs indicate how many pattern pages the active pattern consists of and which pattern page is currently active. The LED flashes on the pattern page currently playing. The secondary function accesses the SCALE menu.
- 20 **[STOP]** stops playback. The secondary function is a paste operation.
- 21 **[PLAY]** starts the playback of the sequencer. The secondary function is a clear operation.
- 22 **[RECORD]** key. Activates/deactivates GRID RECORDING mode. Keep **[RECORD]** pressed, then press **[PLAY]**, to activate LIVE RECORDING mode. Activate/deactivate QUANTIZATION of LIVE RECORDING by keeping

- [RECORD]** pressed, then tapping **[PLAY]** twice. The secondary function is a copy operation.
- 23 **<BANK GROUP>** LED indicates if bank group A-D or E-H will be accessed by the **[BANK]** keys.
- 24 **[BANK D/H]** accesses pattern selection for either bank D or H. The secondary function is SLIDE.
- 25 **[BANK C/G]** accesses pattern selection for either bank C or G. The secondary function is SWING.
- 26 **[BANK B/F]** accesses pattern selection for either bank B or F. The secondary function is ACCENT.
- 27 **[BANK A/E]** accesses pattern selection for either bank A or E. The secondary function is TRIG MUTE.
- 28 **[BANK GROUP]** key. Toggles the active bank group, A-D or E-H. The secondary function toggles between different PATTERN play modes (DIRECT JUMP/SEQUENTIAL/DIRECT START). The <PATTERN MODE> LED, directly below this key, shows these modes as green, off and red, respectively.
- 29 **[TRIG]** keys are used for entering or removing sequencer trigs, in combination with the **[PADS]**, and parameter locks, in combination with the **DATA ENTRY** knobs. Also used to select pattern, when one of the **[BANK]** keys has been pressed.
- 30 **<TRIG>** LEDs show trigs on the sequencer by a fully lit LED, while parameter locks are shown as flashing LEDs, in GRID RECORDING mode. When a pattern is playing, or when LIVE RECORDING is enabled, a fully lit LED runs along the 16 steps of the sequencer across all (up to four) pages at the set TEMPO.
- 31 **[RETRIG]** key will, if pressed in combination with one of the **[PADS]**, continuously retrig the Sound. It also lets you assign custom retrigs for each of the drum tracks on a side menu appearing on the LCD screen whenever the key is pressed. Secondary function opens the CLICK TRACK menu.
- 32 **[FUNCTION]** key. Press, hold and press another key to access the secondary function of that key. Secondary functions are seen in red writing on the Analog Rytm front panel.
- 33 **[TRACK]** key. Press **[TRACK]** + one of the **[PADS]** to select a drum track for editing or for CHROMATIC play. Note that the FX track has its own dedicated key. The secondary function opens the GLOBAL menu where the global settings (SYNTH, SEQUENCER, MIDI et cetera) for the current PROJECT are made. PROJECTS are managed in the GLOBAL menu as well.

## REAR

- 1 Power On/Off switch.
- 2 Power In (12V DC, 2A).
- 3 MIDI Thru.
- 4 MIDI Out.
- 5 MIDI In.
- 6 Individual drum voice outputs CY/CB - RS/CP, CH/OH - MT/HT, SD - LT and BD - BT.
- 7 Audio In.
- 8 Main Out L/R.
- 9 Headphones Out.

See page 20 for recommended connectors.

# SOUND ARCHITECTURE

The illustration below shows the sound architecture of the Analog Rytm, with its eight drum voices, its two send effects (delay and reverb), and its two master effects (distortion and compressor).

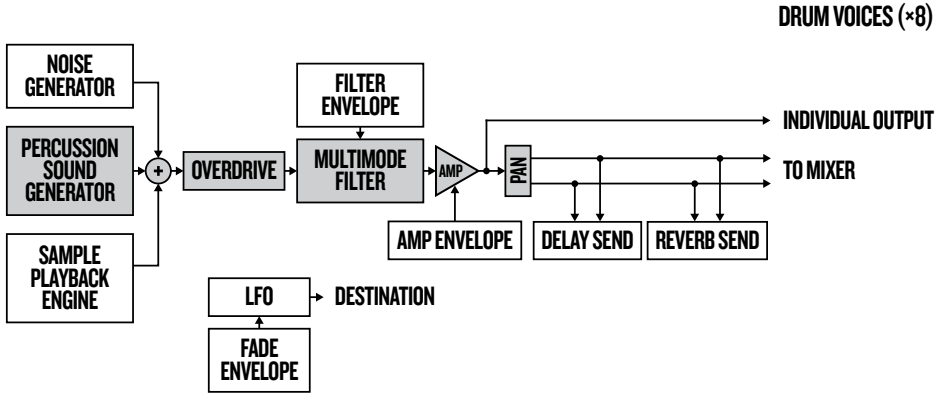

## FX TRACK

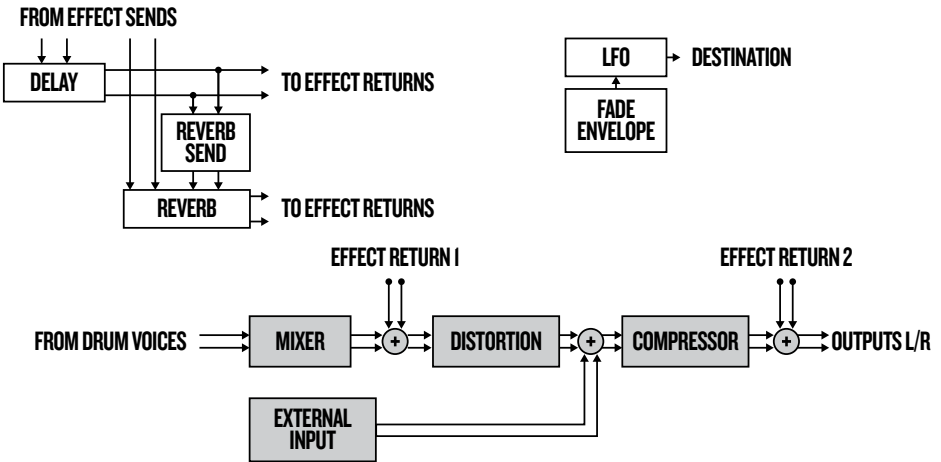

## VOICE CIRCUITS

There are eight analog voice circuits. All voices have an identical sample playback engine, overdrive circuit and multi-mode filter. The percussion sound generators are not identical. Each is designed to generate a specific class of analog drum sounds.

## MACHINES

There are several MACHINES available for each voice circuit. A MACHINE is a set of synthesis parameters that controls a percussion sound generator in order to act like a certain drum model. Different MACHINES are software-tailored to

generate different kinds of bass drums, hihats, et cetera—and to provide the parameters most apt for each particular MACHINE. For example, per default the BD voice makes use of one of the available bass drum MACHINES. Another MACHINE may be selected which will engage the BD voice circuit in a different way, enabling it to employ frequency modulation, ring modulation and more.

## FIRST STEPS WITH THE ANALOG RYTM

### SETTING UP AND STARTING THE ANALOG RYTM

Make sure you place the Analog Rytm on a stable support, such as a sturdy table with sufficient cable space or mount on a rack capable of a 3 kg load.

- 1 Before you connect the Analog Rytm to other equipment, make sure all units are switched off.
- 2 Plug the included PSU-3 adapter to a power outlet and insert the small plug into the Analog Rytm Power In.
- 3 Connect the Main Out L/R from the Analog Rytm to your mixer or amplifier.
- 4 Switch on all units. Switch on the Analog Rytm by pressing the Power rocker switch located at the back of the unit. Before restarting the unit, wait 2 seconds after the LCD backlight goes out.

### THE USER INTERFACE

The LCD screen shows all the information needed for real-time interaction and editing on the Analog Rytm. The eight **DATA ENTRY** knob parameters shown will vary depending on the given situation. The main interface screen is shown below:

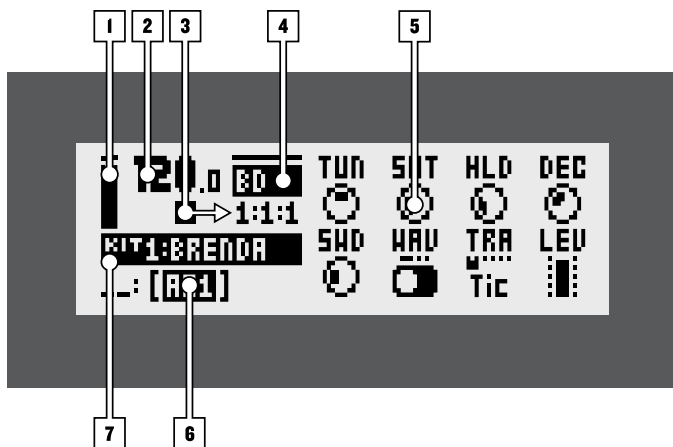

- 1 Bar showing the main volume setting of the active track. Turn **LEVEL** knob to change.
- 2 The current tempo shown with one decimal.
- 3 The playback/recording status of the sequencer shown with the standard »record«, »play«, »pause« and »stop« symbols; ● ▶ || ■. To the right is a counter displaying how many bars, beats and steps the sequencer has played.
- 4 Shows the current **PARAMETER** page.
- 5 Eight track **Sound** parameters. They show what the **DATA ENTRY** knobs control and their current parameter values. Press and turn a knob to adjust its parameter in larger increments.
- 6 The active pattern.
- 7 The active kit. When turning a **DATA ENTRY** knob, the full name of the parameter is shown here. When the active track is changed, the name of the track **Sound** is briefly shown.

## SCREEN NAVIGATION

When entering a menu or sub-menu, navigation is done using the [ARROW] keys [UP], [DOWN], [LEFT] or [RIGHT]. The **LEVEL** knob can be used to quickly scroll through menus and lists.

[YES/SAVE] is used to affirm, select, enter sub-menus and tick/untick boxes.

[NO/RELOAD] is used to negate, deselect or go back one or more steps.



When on a menu or sub-menu the [NO/RELOAD] key can be used to go back, one step at a time, all the way to the main screen.

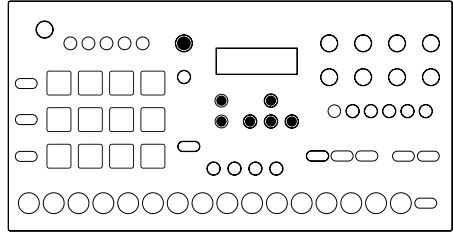

## PADS

The left half of the Analog Rytm front panel is dominated by the 12 pads. The finger-sized buttons are made of tough synthetic rubber and respond to pressure. Tapping a pad will trigger its track sound. BD will trigger the bass drum, SD the snare drum and so on. The twelve drum tracks and their default **MACHINES** are shown below.

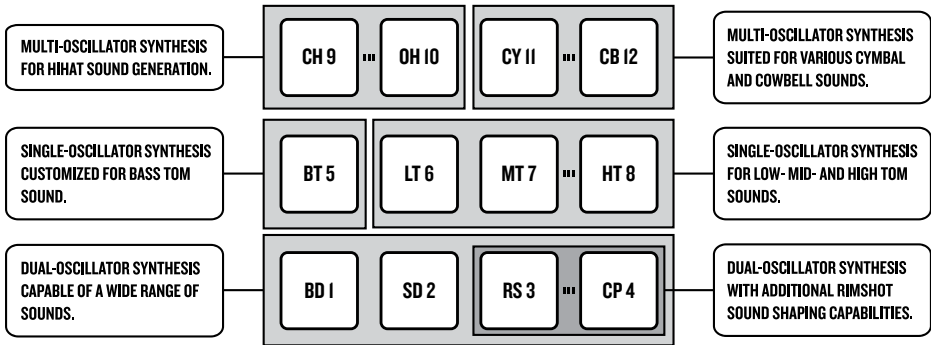

### PAD (DRUM TRACK):

- 1 BD (Bass Drum)
- 2 SD (Snare Drum)
- 3 RS (Rim Shot)
- 4 CP (Hand Clap)
- 5 BT (Bass Tom)
- 6 LT (Low Tom)
- 7 MT (Mid Tom)
- 8 HT (Hi Tom)
- 9 CH (Closed Hihat)
- 10 OH (Open Hihat)
- 11 CY (Cymbal)
- 12 CB (Cow Bell)

### MACHINE (DEFAULT):

- 1 BDHD (BD Hard)
- 2 SDHD (SD Hard)
- 3 RSHD (RS Hard)
- 4 CPCL (CP Classic)
- 5 BTCL (BT Classic)
- 6 XTCL (XT Classic)
- 7 XTCL (XT Classic)
- 8 XTCL (XT Classic)
- 9 CHCL (CH Classic)
- 10 OHCL (OH Classic)
- 11 CYCL (CY Classic)
- 12 CBCL (CB Classic)

Play the track Sounds of the active kit using the [PADS]. 8 individual track Sounds can be voiced simultaneously. The BD, SD, BT and LT are independent tracks. Tracks RS-CP, MT-HT, CH-OH and CY-CB, each pair shown with a coupling on the front panel of the Analog Rytm, share a voice. If both tracks of a coupled pair are played or triggered simultaneously, track CP will choke track RS, HT will choke MT, OH will choke CH and CB will choke CY.



The color of the <PADS> will show pad activity. A pad will flash white briefly when engaged, whether it is played manually or engaged by the Analog Rytm sequencer. The active drum track is shown with a red color pad. <PADS> collectively show, by color, which mode Analog Rytm is in, MUTE mode or CHROMATIC mode, for example. Read more about these modes in the following section.

## EXPERIMENTING WITH BEAT PATTERNS

You will find several preset patterns, kits and Sounds in the Analog Rytm. Follow the instructions below to get started exploring your new instrument.

- 1 Switch on the Analog Rytm.
- 2 Make sure bank group A-D is selected. <BANK GROUP> LED must be lit in its upper position. If it is not, press the [BANK GROUP] key to toggle.
- 3 Press [BANK A/E] + [TRIG] key 1 to select the first pattern of bank A.
- 4 Press [PLAY] to listen to pattern AO1.
- 5 Press [BANK A/E] + [TRIG] key 2 to select pattern AO2. It will start once pattern AO1 has reached its final step. Select pattern AO3 by pressing [BANK A/E] + [TRIG] key 3, and so on.
- 6 Press [STOP] to stop playback.

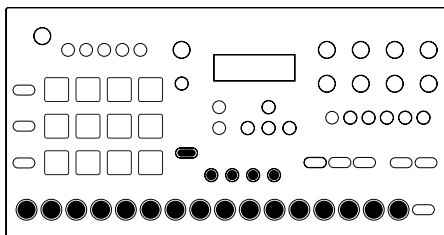

## PERFORMANCE MODE

The PERFORMANCE mode enables each one of the twelve pads to control several PARAMETER page parameters at once. Change many dimensions of one or more drum track Sounds at the touch of a single pad. A set of such parameter mappings is called a performance macro. Try out the preset macros:

- 1 Make sure a pattern is playing.
- 2 Press the [PERFORMANCE] key to enter PERFORMANCE mode.
- 3 Press one of the [PADS]. Apply different pressures and listen how the sound of the pattern changes.

## SCENE MODE

The SCENE mode turns the twelve pads into instant sound shifters. Similar to a parameter macro, several parameters from any track can be changed by pressing a single pad. A scene, however, is a fixed set of parameter values, ready to be activated or deactivated. By carefully assigning a set of parameter values to a scene, you can prepare a shell that will make the same kit sound drastically (or subtly) different whenever activated. Try out the preset scenes by following the instructions below. The active scene is shown with a full-bright green color pad.

- 1 Make sure a pattern is playing.
- 2 Press the [SCENE] key to enter SCENE mode.
- 3 Tap one of the [PADS] 1-12 to activate a scene. Tap again to deactivate.

## CHROMATIC MODE

Any track Sound may be played chromatically using the 12 pads. The chromatic note pitch is increased for each successive pad pressed: left to right, bottom to top. Twelve successive pads make one octave. The range spans four octaves, middle, one up and two down. The middle octave has sky blue color <PADS>, the two below are of violet and dark blue color, in that order, and the one above is of olivine color.

- 1 Make sure a pattern is playing.
- 2 Press the [CHROMATIC] key to enter CHROMATIC mode.
- 3 Play the [PADS]. The active track Sound will be pitched differently for each of the 12 pads comprising the middle octave. Reach higher or lower octaves, one row at a time, by pressing [ARROW] keys [UP] or [DOWN], respectively.



The CHROMATIC mode is an effective way to add musical variety to your beats. The timbre, tonality and impact of playing a Sound chromatically depends on the track type and how the Sound is designed. The synth part, the sample part or both synth and sample part of the Sound may be chromatic enabled. This is done in the SOUND SETTINGS of the SOUND menu. Some Sounds are more suited for chromatic variation than others.

## MUTE MODE

- 1 Mute the sequencer on any of the twelve drum tracks in this mode. Unlike the CHROMATIC mode, it makes no difference which track is active when this mode is activated. All tracks are accessed simultaneously.
- 2 Make sure a pattern is playing.
- 3 Press the [MUTE] key to enter MUTE mode.
- 4 Press any of the [PADS] to mute the corresponding track. Press again to unmute. The color of the <PADS> indicate the mute status. Unlit <PADS> are muted. Green <PADS> are audible.
- 5 Press and hold [FUNCTION] and then any of the [PADS] in order to preselect a mute, or mute/unmute several tracks in one go. Once you release [FUNCTION], the selected mutes will come into effect. Preselected mutes are shown as <PADS> of blue color.



Press [RETRIG] and one of the [PADS] if you wish to activate solo, in other words mute all tracks except the one selected. Press again to deactivate solo. Keeping [RETRIG] pressed, multiple tracks may be solo activated/deactivated. Solo activated <PADS> are of sky blue color. This only works in MUTE mode.

## TEMPO

On the main interface screen, press and hold [ARROW] keys [LEFT] or [RIGHT] to nudge the tempo 10% up or down. Release to revert the BPM to its original setting.



To change the overall BPM setting, open the TEMPO screen by pressing the [TEMPO] key.

Use the LEVEL knob to change tempo in integer steps. Pressing the knob while turning it changes the tempo eight steps at a time. The [ARROW] keys [UP] or [DOWN] change the tempo in fractional steps.

## SETTING PARAMETERS

Each drum track has five PARAMETER pages, accessed by pressing [PARAMETER] keys SYNTH, SAMPLE, FILTER, AMP, and LFO. The parameters found here affect the sound in various ways. When the FX track is active, the corresponding PARAMETER pages are DELAY, REVERB, DISTORTION, COMPRESSOR and LFO, accessed by the same keys.

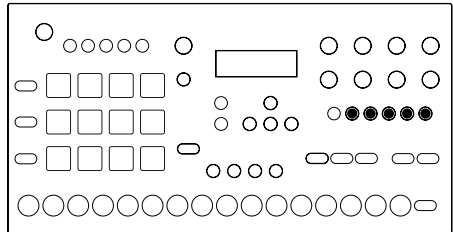

- 1 Make sure a pattern is playing.
- 2 Press [TRACK] + [PADS] 1-12 to select one of the twelve drum tracks.
- 3 To change, for example, the cutoff frequency of the filter, press the FILTER key. The FILTER page will be shown on the LCD screen. The parameter labelled FRQ changes the cutoff of the filter. Turn DATA ENTRY knob E to change the parameter value, and hear how the Sound is affected.
- 4 Try out the rest of the PARAMETER page parameters to explore a variety of sound shaping possibilities.
- 5 To reload the Sound to its original state, press [NO/RELOAD] + [MUTE].
- 6 To reload the whole kit to its original state, press [NO/RELOAD] + [FX].
- 7 To save kit changes, press [YES/SAVE] + [FX].

## OVERVIEW OF THE ANALOG RYTM DATA STRUCTURE

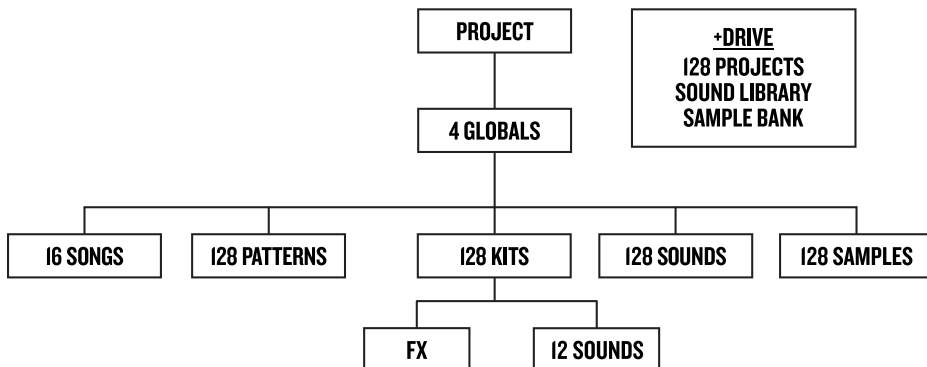

### +DRIVE

The +Drive is the non-volatile memory of the Analog Rytm. It keeps up to 128 projects (thousands of patterns, kits and songs) stored internally. The +Drive also gives access to the +Drive Sound library, capable of storing 4096 drum Sounds, and a Sample bank. All projects have access to these Sounds and samples.

### PROJECT

A project contains 128 patterns, 128 kits, 16 songs, 4 global slots, 128 sample slots and a project Sound pool consisting of up to 128 Sounds. Generic settings and states are stored in the project. When a project is loaded it becomes the active working state of the Analog Rytm. From here it is possible to edit the patterns, kits, songs and globals of the project. Every time the Analog Rytm is switched on, it boots to the active working state, the active project. Projects are saved, loaded and managed in the GLOBAL menu.

### SAMPLE

128 user samples are available for each project. There are many preset samples to choose from in the +Drive Sample bank. Additional samples need to be loaded to the Analog Rytm from a computer with the complimentary C6 utility software.

### KIT

A kit is a collection of twelve drum track Sounds and an FX track. When editing a track, any changes made to the settings will be stored only to the active kit. Each project of the Analog Rytm contains 128 individual kits. A pattern always links to one of the kits.

### SOUND

A Sound consists of an array of parameter settings found in the PARAMETER pages called SYNTH, SAMPLE, FILTER, AMP and LFO. Sounds are stored in the Sound pool of the active project or in the +Drive Sound library. The Sound pool has 128 Sound slots and the +Drive Sound library holds up to 4096 sounds.

### PATTERN

For each of the 8 banks there are 16 patterns, which means 128 patterns are always readily available for each project. A pattern contains sequencer data like drum trigs, mutes and parameter locks for the drum tracks and the FX track, as well as default settings on the TRIG page and length, swing and time signature settings.

### SONG

16 songs are available for each project. They are used to sequence the playback of patterns. Songs are built of patterns and chains.

## GLOBAL

The GLOBAL menu contains overarching settings for the synth and sequencer, Analog Rytm MIDI setup, OS upgrade and SysEx data handling. Four global slots are available for each project, each with its own specific settings. Also, projects are saved, loaded and managed in this menu.

## ABOUT THE TRACKS

### THE DRUM TRACKS

There are 12 drum tracks. To select a track for editing, press and hold [TRACK] key and then press one of the [PADS]. Each drum track uses a specific drum voice controlled by one of the MACHINES available for the voice. All drum tracks are able to layer analog percussion sounds and sampled sounds, to distort and filter them, and apply a dedicated LFO each.

### THE FX TRACK

The FX track controls the Analog Rytm send effects DELAY and REVERB, as well as the DISTORTION and COMPRESSOR master effects. One LFO is also available for this track. To select the FX track for editing, press the [FX] key.

### EDITING THE TRACKS

The five [PARAMETER] keys open parameter pages that are used for editing the tracks. The SYNTH page of a drum track contains different parameters depending on the MACHINE chosen for the analog percussion sound generator. The other pages are identical for all drum tracks; the SAMPLE page for the sample playback engine, the FILTER page for the multimode filter and its filter envelope, the AMP page for the amplitude envelope and effect sends etcetera, and the LFO page for the low-frequency oscillator. The corresponding five parameter pages for the FX track controls the four effects and the FX LFO. Edit parameters using the DATA ENTRY knobs A-H. Press and turn a knob to adjust its parameter in larger increments.

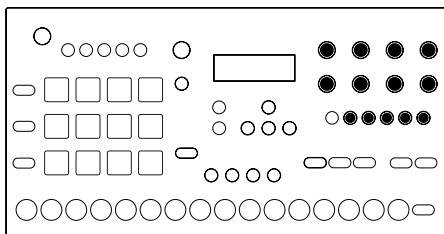
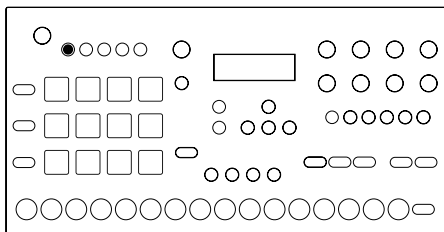
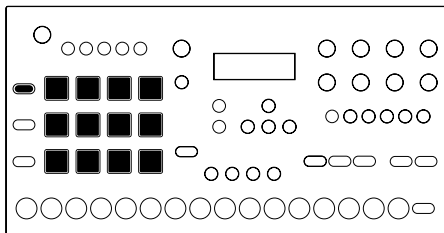

## KITS AND SOUNDS

Every project has the capacity of 128 different kits. A kit is a collection of 12 drum track Sounds and an FX track, and their specific parameter settings. A Sound is composed of synth, sample, filter, effect sends, envelope and LFO settings in any combination. Sounds are assigned to the twelve drum tracks.

A Sound that has been loaded to a track becomes a part of the active kit. Any changes made to a track Sound will not affect the stored Sound, it will affect and become part of the active kit. A pattern, controlling the playback of the kit, always links to a specific kit (non-exclusively). Any changes to the kit will affect other patterns using the same kit. When the Analog Rytm is switched off, only the active kit preserves its changes. Other kits must be saved.

When you create a brand new pattern, using an existing kit that is already linked to another pattern, we recommend that you save and rename the kit, first thing you do (see below). Unless, of course, you intend kit changes to affect multiple patterns.

## LOADING A KIT

- 1 Open the KIT menu by pressing **[FUNCTION] + [FX]**.



- 2 Use the **[ARROW]** keys **[UP]** and **[DOWN]** or the **LEVEL** knob to select **LOAD KIT**. Press **[YES/SAVE]** to open the menu.

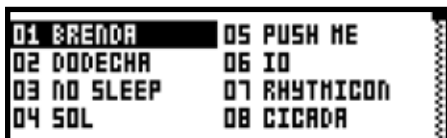

- 3 The **LOAD KIT** menu contains up to 128 saved kits. The current active kit is shown with inverted graphics. Select the kit to be loaded using the **[ARROW]** keys or the **LEVEL** knob.
- 4 Once a kit has been selected, press **[YES/SAVE]** to load it. The active pattern will now be linked to the loaded kit.

## SAVING A KIT

- 1 Open the KIT menu by pressing **[FUNCTION] + [FX]**.



- 2 Use the **[ARROW]** keys **[UP]** and **[DOWN]** or the **LEVEL** knob to select **SAVE KIT**. Press **[YES/SAVE]**.
- 3 Select the position to which the kit should be saved by using the **[ARROW]** keys or the **LEVEL** knob.
- 4 Once a position has been selected, press **[YES/SAVE]** to save the kit. The naming screen will appear. Read more about naming on page 16. Quickly save changes to an active kit by pressing **[YES/SAVE] + [FX]**.

## LOADING A SOUND TO A DRUM TRACK

- 1 Select the drum track to which the Sound will be loaded to by pressing **[TRACK] + [PADS] 1-12**.

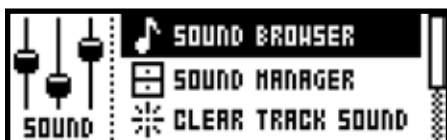

- 2 Open the **SOUND** menu by pressing **[FUNCTION] + [MUTE]**.
- 3 Use the **[UP]** and **[DOWN]** arrow keys to select **SOUND BROWSER**. Press **[YES/SAVE]** to open the menu. The **SOUND BROWSER** shows a list of all Sounds in either the +Drive Sound library or the Sound pool. Only the Sounds that can be voiced by the active track will be shown. Scroll the list by turning the **LEVEL** knob or by pressing **[ARROW]** keys **[UP]** or **[DOWN]**.



- 4 Here, the +Drive Sound library is browsed. If the track Sound is to be loaded from the Sound pool instead, press the [LEFT] arrow key. The SORTING menu will open. Highlighting the first option in the menu and pressing [YES/SAVE] switches between browsing the +Drive Sound library and the Sound pool.



- 5 Load a Sound into the kit by pressing [YES/SAVE].

### SAVING A SOUND

- 1 Open the SOUND menu by pressing [FUNCTION] + [MUTE].

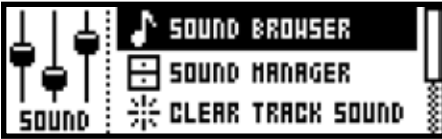

- 2 Use the [ARROW] keys [UP] and [DOWN] or the LEVEL knob to select SOUND MANAGER. Press [YES/SAVE] to open. The SOUND MANAGER is a more powerful version of the SOUND BROWSER. Here, track Sounds can be saved, loaded, tagged, locked et cetera. Scroll the list by turning the LEVEL knob or by pressing [ARROW] keys [UP] and [DOWN].



- 3 Here, the +Drive Sound library is browsed. If you wish to save the Sound to the Sound pool instead, press the [LEFT] arrow key. The SORTING menu will open. Highlighting the first option in the menu and pressing [YES/SAVE] switches between browsing the +Drive Sound library and the Sound pool.



- 4 Select an empty slot. Press [RIGHT] to access the SOUND OPERATIONS menu. The operations will affect the currently highlighted Sound.



- 5 Select STORE TRACK SOUND. Press [YES/SAVE] to store it to the selected slot.  
 6 The NAMING menu will appear. Read more about this menu on page 16.

## LOADING A SAMPLE TO A DRUM TRACK

- 1 Select a drum track by pressing **[TRACK]** + one of the **[PADS]**.
- 2 Open the **SAMPLE** parameter page by pressing **[PARAMETER]** key 2.

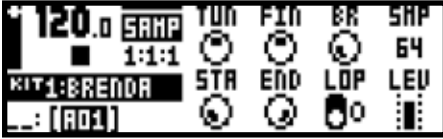

- 3 Press **DATA ENTRY** knob C to bring up a list of samples.



- 4 Turn the knob counter-clockwise to scroll up the list, clockwise to scroll down the list. Tap the pad of the active track while browsing to listen to the sample currently outlined.
- 5 To select an outlined sample, press **[YES/SAVE]**. Press **DATA ENTRY** knob C or **[NO/RELOAD]** to exit the list without selecting a sample.



Sample selection may also be accessed by quickly pressing the second **[PARAMETER]** key, **SAMPLE**, twice.

## PLAYING A TRACK SOUND

- 1 Play by tapping any of the twelve **[PADS]**. **<PADS>** will briefly flash white when tapped.
- 2 Experiment by tapping the pads rhythmically with your fingertips. Each pad is velocity sensitive, which means a gentle rap and a decisive stab on the pad will produce drum sounds of different intensities.
- 3 Press and hold **[RETRIG]**, then press and hold any of the **[PADS]** to continuously retrigger the track Sound for as long as the pad is held. Play drum rolls in this manner on one or several of the pads, each with its own assignable retrigger speed. Set retrigger speed using the **LEVEL** knob.
- 4 Sounds that are designed for aftertouch play may be played by tapping and then pressing a pad without lifting your finger in between.

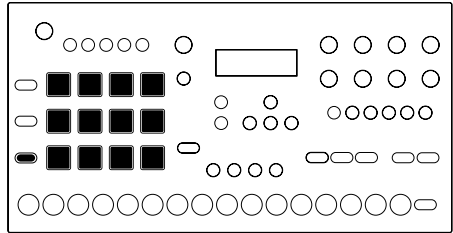

## EDITING A TRACK SOUND

- 1 Activate one of the drum tracks for editing by pressing **[TRACK]** + one of the **[PADS]**. The pad of the active track will turn red. The information bar on the LCD screen which shows the loaded kit will briefly change to show the name of the drum track Sound. When editing, the **MACHINE**, Sound and sample settings of the track can be changed, and any changes made will be stored as part of the active kit.
- 2 Adjust the overall volume level of the active drum track Sound with the **LEVEL** knob.

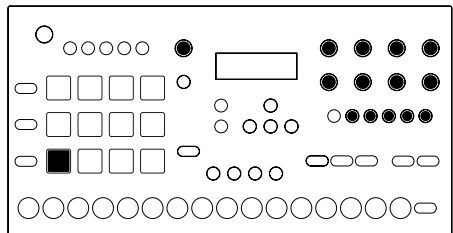

3 The current MACHINE in use will determine which SYNTH parameters will be available for Sound modulation. Quickly press the first [PARAMETER] key, SYNTH, twice to bring forth a menu for MACHINE selection.



- 4 Browse through the MACHINE list using the [ARROW] keys [UP] and [DOWN]. Sample the MACHINE currently outlined by tapping the pad of the active track. Select the outlined MACHINE by pressing [YES/SAVE]. Exit without switching MACHINE by pressing [NO/RELOAD].
- 5 Edit a track Sound by adjusting the parameters found on the PARAMETER pages. Access these pages by pressing one of the five [PARAMETER] page keys. Use the DATA ENTRY knobs A-H to change the parameters.

SYNTH controls the oscillator tuning and other physical properties of the Sound.

SAMPLE controls the sample selection and settings.

FILTER controls the filter mode, cutoff frequency and envelope.

AMP controls the amplitude parameters.

LFO controls parameters for the LFO of the active track.

### EDITING THE FX TRACK

- 1 Select the FX track for editing by pressing the [FX] key.
- 2 Set the volume level of the DELAY and REVERB parameters of the FX track with the LEVEL knob.
- 3 Access the PARAMETER pages for the FX track by pressing one of the five [PARAMETER] page keys. Use the DATA ENTRY knobs A-H to change the parameters.

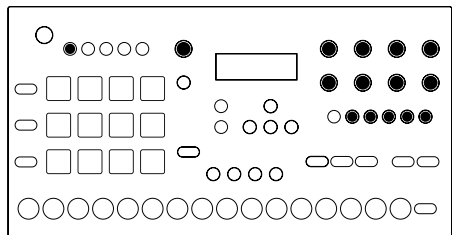

DELAY controls the time, filter, volume et cetera of the delay.

REVERB controls the pre-delay, filters and volume of the reverb.

DISTORTION controls the amount of distortion applied.

COMPRESSOR controls the threshold value, ratio and dry/wet mix of Sound compression.

LFO controls parameters for the FX track LFO.

### THE NAMING SCREEN

The naming procedure is identical for the various naming situations that appear when kits, Sounds, patterns, songs or projects are saved or renamed.



- 1 Use [ARROW] keys [LEFT] and [RIGHT] to navigate between the letters.
- 2 Press and hold [FUNCTION] to access the pop-up naming menu.





- 3 Navigate between the letters in this menu using the **[ARROW]** keys.
- 4 Release **[FUNCTION]** to insert the letter. Repeat the procedure for each successive letter.
- 5 Press **[YES/SAVE]** when you are done naming.

## THE SEQUENCER

---

### BASIC PATTERN OPERATIONS

The sequencer of the Analog Rytm stores information in patterns. A pattern controls the playback of each of the drum tracks and the FX track by the trigs entered on the sequencer.

### SELECTING A PATTERN

- 1 Press the **[BANK GROUP]** key to toggle bank group. If, for example, bank group A-D is selected, patterns in banks A, B, C and D can be accessed.
- 2 Next, press a **[BANK]** key followed by a **[TRIG]** key (1-16) to select a pattern within the selected bank. Patterns containing data are shown by half-bright red <TRIG> LEDs. The currently active pattern is shown by a full-bright red <TRIG> LED. Empty pattern slots are shown with unlit <TRIG> LEDs.
- 3 To select, for example, pattern B05, select bank group A-D using the **[BANK GROUP]** key. Then press and hold **[BANK B/F]** and press **[TRIG]** key 5.

### PATTERN CONTROL

Pressing **[PLAY]** will start the playback of a pattern. Pause by pressing **[PLAY]** again. Pressing **[STOP]** will stop the playback of all tracks. The sound will be cut off, but effects like the delay will continue to be heard until the delay repeats have faded out. Quickly press **[STOP]** twice to stop playback of all tracks and fade out the send effects.

### PATTERN MODES

When changing patterns, the new pattern can be started in three ways. Toggle between the PATTERN modes by pressing **[FUNCTION] + [BANK GROUP]**. The LCD screen will briefly show which mode is activated. The <PATTERN MODE> LED will permanently show which mode is active.

**DIRECT START** will immediately change patterns. The new pattern will start playing from the beginning. Shown by a red <PATTERN MODE> LED.

**DIRECT JUMP** will immediately change patterns. The new pattern will start playing from the position where the previous pattern left off. Shown by a green <PATTERN MODE> LED.

**SEQUENTIAL** will change patterns after the currently playing pattern reaches its end. This mode is the default mode. Shown by an unlit <PATTERN MODE> LED.

### PATTERN RECORDING MODES

The Analog Rytm offers two main modes of inputting trigs when creating a pattern: GRID RECORDING mode and LIVE RECORDING mode. To create a new pattern, first select an empty pattern slot in one of the banks.

### TRIG TYPES

Two types of trigs, note trigs and trigless locks, can be entered in the RECORDING modes. Note trigs trigger notes (Sounds of the chosen drum track) while trigless locks can be used to apply parameter locks without triggering notes (see PARAMETER LOCKS on the following page). Setting SYN and SMP (on the TRIG page) to zero on a trig will turn it into a trigless lock. Note trigs are indicated by full-bright <TRIG> LEDs and trigless locks are indicated by half-bright <TRIG> LEDs. <TRIG> LEDs above steps not containing any trigs remain unlit.

## TRIG SETUP

Press **[TRIG SETUP]** in order to specify the trig actions for the active track: activate/deactivate the Synth part or the Sample part of the track Sound, for example. Use the **DATA ENTRY** knobs to change settings.

## GRID RECORDING MODE

GRID RECORDING is a method of composing where trigs are added by using the **[TRIG]** keys.

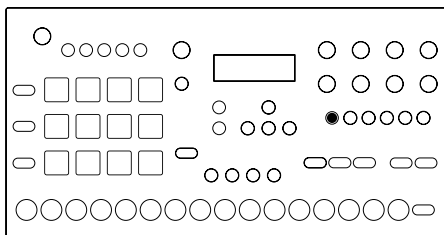

- 1 Enter GRID RECORDING mode by pressing the **[REC]** key. A lit red <REC> LED indicates GRID RECORDING mode is active.
- 2 Select the track to which you want to add trigs by pressing and holding **[TRACK]** and then one of the **[PADS]**. This is now the active track, shown by one of the <PADS> glowing red.
- 3 Place note trigs on the sequencer using the 16 **[TRIG]** keys. To add a trigless lock, press **[FUNCTION]** and **[TRIG]** (see **PARAMETER LOCKS** below). Trigless locks may be entered on any step of the sequencer, including ones containing note trigs. Quickly pressing the **[TRIG]** key of any of the trigs entered will remove the trig. Pressing a **[TRIG]** key of a trig and holding it slightly longer will prepare the trig for editing, rather than removing it.
- 4 Select another track, and add note trigs and/or trigless locks. Repeat the procedure for all the tracks you want to use.
- 5 Press **[PLAY]** to listen to the sequence.

## LIVE RECORDING MODE

LIVE RECORDING mode is the second method of adding trigs to the tracks. In this recording mode, all the **[PADS]** are played in real time to input trigs to the tracks. It is also possible to enter parameter locks in real time.

- 1 Press and hold **[RECORD]**, then press **[PLAY]** to enter LIVE RECORDING mode. Quickly pressing **[PLAY]** twice while keeping the **[RECORD]** key pressed will activate/deactivate quantization of LIVE RECORDING. The sequencer will start to play and the <RECORD> LED will start to flash.
- 2 Enter trigs to all tracks of the sequencer in real time by tapping the **[PADS]**.
- 3 Press **[PLAY]** to exit LIVE RECORDING mode while keeping the sequencer playing. If LIVE RECORDING mode is active and **[REC]** is pressed, GRID RECORDING mode will be activated.
- 4 Press **[STOP]** to stop both the recording and the playback of the sequencer.

## SEQUENCER FEATURES

### PARAMETER LOCKS

Parameter locks allow trigs to have their own unique parameter values. All note trigs of a track may, for instance, have different pitch or filter settings. Parameter locks can be applied to any type of track.

- 1 In GRID RECORDING mode, press and hold the **[TRIG]** key of a trig to apply parameter locks.
- 2 Adjust the parameters you want to lock using the **DATA ENTRY** knobs. The graphics on the LCD will become inverted for the locked parameter and the locked parameter value will be shown. The <TRIG> LED of the locked trig will begin to flash, signalling that the trig now contains a parameter lock.
- 3 Remove a single parameter lock by holding **[TRIG]** + pressing the **DATA ENTRY** knob of the locked parameter. By removing a note trig and entering it again, all parameter locks will be erased from the trig.

In LIVE RECORDING mode, turn a **DATA ENTRY** knob to input parameter locks to the active track. The parameter will be locked accordingly and placed on the sequencer steps.

## PATTERN SCALE

The length and timing of the pattern can be changed on this screen. The leftmost figure shows the number of steps in the pattern. The maximum number of steps is determined by the total length, which is shown on the right. The rightmost figure controls the time signature of the pattern. If 17 steps or more are used in a pattern, the [PAGE] key can be used to toggle between the different pattern pages when in GRID RECORDING mode.



- 1 Press [FUNCTION] + [PAGE] to access the scale screen.
- 2 Use the [ARROW] keys [LEFT] and [RIGHT] to toggle between step length/total length or time signature.
- 3 Use the [ARROW] keys [UP] and [DOWN] to change the settings. The **LEVEL** knob can be used to change settings as well.

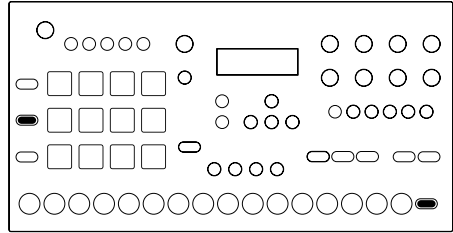

## PATTERN SWING

Adjust the swing setting of the pattern, in order to employ a propulsive, rhythmic groove.

- 1 Access this screen by pressing [FUNCTION] + [BANK C/G].
- 2 Set the SWING ratio to 51-80%, by turning the **LEVEL** knob or by pressing [ARROW] keys [UP] or [DOWN]. The default setting is equal spacing, 50%

## MAKING A SIMPLE BEAT

The following is a step-by-step instruction on how to make a basic beat pattern on the Analog Rytm, using a variety of techniques shown in this quick start guide. Re-visit the previous sections if you are unsure of how to employ the techniques.

- 1 Select a free pattern slot from one of the eight banks.
- 2 Load a kit, then save it and give it a new name.
- 3 Set the TEMPO to 120 BPM, then activate GRID RECORDING.
- 4 Set the TRIGS shown below on the following five tracks:

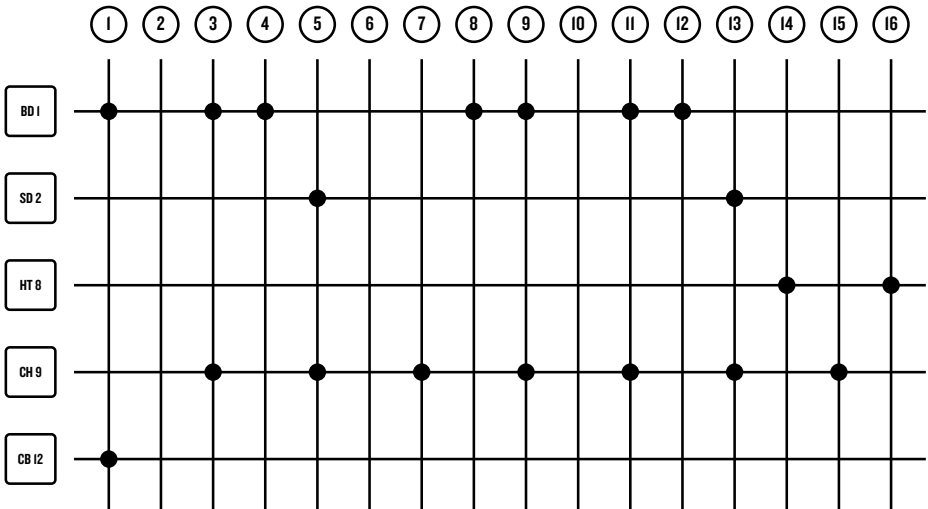

- 5 Press [PLAY] to listen to the pattern.

- 6 On the BD track, set a few parameter locks. Experiment with the parameters on the SYNTH page. Set some trigless locks. See if you can prolong the sound on a note trig, then make the sound walk on the next few steps using trigless locks and different TUN settings. Switch MACHINE for the BD and try out the new parameters available on the SYNTH page. On the FILTER page, experiment with FRQ and RES parameters.
- 7 Experiment with the other parameter pages on the BD track, then on the SD, HT, CH and CB track as well.
- 8 Exit GRID RECORDING. Tap the toms rhythmically. Add some rimshot and claps for good measure. Try out the CHROMATIC and SCENE modes. Once you know where you want to go with the beat, activate LIVE RECORDING and tap away to complete the pattern. To top it off, add some SWING.

## FACTORY RESET

When performing a factory reset on the Analog Rytm it will overwrite and re-initialize the active RAM project (including all pattern, kit, sound pool and global data). The +Drive project slot 1 will be overwritten and re-initialized. Sound bank A will be overwritten with the factory Sounds. Factory preset patterns, kits, Sounds and settings will be re-initialized.

If you wish to keep the active project, remember to save it to a +Drive project slot higher than 1 before you perform a factory reset. To perform a factory reset, hold **[FUNCTION]** pressed while turning on the Analog Rytm. In the menu that appears, press the third **[TRIG]** key.

## ANALOG RYTM ACCESSORIES

### RACK MOUNT KIT

When rack mounted, the Analog Rytm occupies four standard height units plus additional space, usually about 1 U, which is needed to accommodate cables plugged into the unit. A 1 U empty rack space below the Analog Rytm is recommended for ventilation purposes.

When assembling the rack mount kit, we recommend using a Phillips screwdriver of suitable size. Use the included M3×6 mm size screws to secure the rack mount consoles on each side of the Analog Rytm.

### ECC-2 CARRYING BAG AND PL-2 PROTECTIVE LID

The carrying bag holds one Analog Rytm. The protective plastic lid is put on top of the Analog Rytm panel in order to protect the LCD display and the knobs. When you purchase the bag you get a complementary protective lid.

For a complete list of accessories please visit [www.elektron.com](http://www.elektron.com).

## RECOMMENDED CONNECTORS

**Power In (12 V DC, 2A)** Use the included PSU-3 power adapter or equivalent connected to a power outlet.

**Full-speed USB 2.0 Connection:** Connect using the included A to B USB 2.0 connector cable to a computer host.

**MIDI Thru:** Use standard MIDI cable to connect another MIDI unit in chain. Duplicates incoming MIDI In data stream.

**MIDI Out:** Use standard MIDI cable to connect to MIDI In of an external MIDI unit.

**MIDI In:** Use standard MIDI cable to connect MIDI Out of an external MIDI unit in order for it to control the Analog Rytm.

**Audio Input:** Use standard ¼" stereo phone plug to input sound from other synthesizers or mixers.

**Individual Stereo Outputs Track 1-12:** Use ¼" insert/Y cable in order to access both left and right channels.

**Main Out L/R:** Use either ¼" mono phone plug (unbalanced connection) or ¼" stereo (Tip/Ring/Sleeve) phone plug (balanced connection).

**Headphones Output:** Connect standard headphones with ¼" stereo phone plug.

# TECHNICAL INFORMATION

---

## SPECIFICATIONS

### THE SEQUENCER

- 12 drum tracks
- 1 FX track
- Up to 64 steps per pattern
- Individual track lengths
- 128 user samples (per project)
- 12 Scenes (per kit)
- Trig mute, accent, swing and slide functions
- Micro timing
- Parameter locks
- Chromatic mode
- Scene mode
- Performance mode
- Versatile and assignable Retrigger
- Live friendly Performance mode
- Sound-per-step change
- Instant kit, pattern and Sound reload
- Full real-time control

### DRUM VOICE × 8

- Fully analog signal path
- 1 × analog percussion sound generator
- 1 × analog overdrive circuit
- 1 × 2-pole analog multi-mode filter
- 1 × stereo VCA
- 1 × filter envelope
- 1 × amp envelope
- 2 × effect sends
- 1 × assignable LFO
- 1 × dedicated LFO fade envelope
- 1 × 16-bit sample playback engine
- 1 × sample bitrate reduction

### SEND EFFECTS

- Delay
- Reverb

### MASTER EFFECTS

- Analog Stereo Distortion
- Analog Stereo Compressor

### STORAGE

- 128 projects (+Drive)
- 128 Kits (per project)
- 128 patterns (per project)
- 16 Songs (per project)
- 4096 sounds (+Drive Sound library)
- 128 Sounds (per project)
- 1GB sample storage (+Drive)
- 64 MB sample storage (per project)
- 128 user samples (per project)

### IMPEDANCE BALANCED AUDIO OUTPUTS

- Main outputs level: +15dBu
- Output impedance: 440 Ω unbalanced

### UNBALANCED AUDIO INPUTS

- Input level: +15dBu maximum
- Audio input impedance: 9 k Ω

### HEADPHONES OUTPUT

- Headphones out level: +15dBu
- Output impedance: 55 Ω

### INDIVIDUAL VOICE OUTPUTS

- Output level: +15 dBu
- Output Impedance: 440 Ω

### ELECTRICAL SPECIFICATIONS

- Unit power consumption: 14 W typical, 20 W maximum.
- Recommended power supply: PSU-3 or similar 12V DC, 2A

### HARDWARE

- 12 synthetic rubber, pressure sensitive and backlit pads
- 122 × 32 pixel backlit LCD screen
- MIDI In/Out/Thru with DIN Sync out
- 2 × ¼" impedance balanced audio out jacks
- 1 × ¼" stereo audio in jack
- 1 × ¼" stereo headphone jack
- 4 × ¼" (TRS) paired individual track output jacks
- 48 kHz, 24-bit D/A and A/D converters
- Flash-EEPROM upgradable operating system
- Electrically isolated multi-functional USB 2.0 port

### PHYSICAL SPECIFICATIONS

- Sturdy steel casing
- Dimensions: W340 × D176 × H63 mm (13.4" × 6.9" × 2.5") (including, power switch, knobs and rubber feet)
- Weight: approximately 2.4 kg (5.3 lbs)

## CREDITS

---

### PRODUCT DESIGN AND DEVELOPMENT

Oscar Albinsson  
Magnus Forsell  
Anders Gärder  
Jimmy Myhrman  
Jon Mårtensson  
David Revelj  
Mattias Rickardsson  
Daniel Troberg

### ADDITIONAL DESIGN

Ufuk Demir  
Thomas Ekelund

### FACTORY DEFAULT SOUND DESIGN

Ufuk Demir  
Thomas Ekelund  
Per Engström  
Antony Klaeboe  
Filip Leyman  
Andreas Lundin  
Jimmy Myhrman  
Jon Mårtensson  
Johan Reivén  
Daniel Troberg  
Cenk Sayinli  
Charlie Storm

### MANUALS

Ufuk Demir  
Thomas Ekelund  
Jon Mårtensson  
Daniel Sterner

## CONTACT INFORMATION

---

### ELEKTRON WEBSITE

[www.elektron.se](http://www.elektron.se)

### DELIVERY ADDRESS

Elektron Music Machines MAV AB  
Sockerbruket 9  
SE-414 51 Gothenburg  
Sweden

### TELEPHONE

+46 (0)31 743 744 0

This Getting Started manual is copyright © 2014 Elektron Music Machines MAV AB. All reproduction without written authorization is strictly prohibited. The information in this manual may change without notice. Elektron's product names, logotypes, titles, words or phrases may be registered and protected by Swedish and international law. All other brand or product names are trademarks or registered trademarks of their respective holders.

**FCC COMPLIANCE STATEMENT**

This device complies with part 15 of the FCC rules. Operation is subject to the following two conditions: (1) This device may not cause harmful interference, and (2) this device must accept any interference received, including interference that may cause undesired operation.

NOTE: This equipment has been tested and found to comply with the limits for a Class B digital device, pursuant to Part 15 of the FCC Rules. These limits are designed to provide reasonable protection against harmful interference in a residential installation. This equipment generates, uses and can radiate radio frequency energy and, if not installed and used in accordance with the instructions, may cause harmful interference to radio communications. However, there is no guarantee that interference will not occur in a particular installation. If this equipment does cause harmful interference to radio or television reception, which can be determined by turning the equipment off and on, the user is encouraged to try to correct the interference by one or more of the following measures:

- Reorient or relocate the receiving antenna.
- Increase the separation between the equipment and receiver.
- Connect the equipment into an outlet on a circuit different from that to which the receiver is connected.
- Consult the dealer or an experienced radio/TV technician for help.

**EUROPEAN UNION REGULATION COMPLIANCE STATEMENT**

This product has been tested to comply with the Low Voltage Directive 2006/95/EC and the Electromagnetic Compatibility Directive 2004/108/EC.  
Meets EU RoHS 2 Directive 2011/65/EU.

This symbol indicates that your product must be disposed of properly according to local laws and regulations.



